

REVISIONS				
P	LTN	DESCRIPTION	DATE	APVD
R		REDRAWN/REVISED PER ECO-17-001745	30NOV2017	KS JO

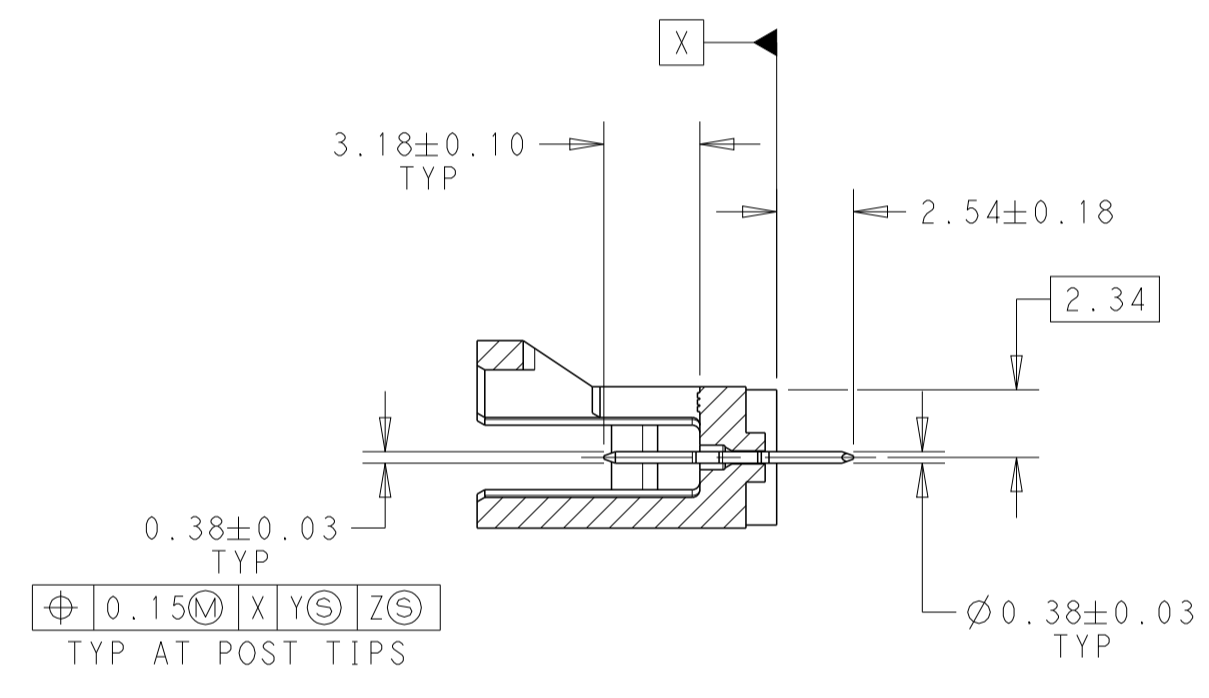

SECTION A - A

- 1 CONTACT AREAS PLATED WITH 0.76µm GOLD, SOLDER TAILS PLATED WITH 3.81µm TIN-LEAD, ALL OVER 1.27µm NICKEL.
- 2. NOTE DELETED
- 3 CIRCUIT IDENTIFICATION FEATURE OMITTED ON 4, 5, 6 & 7 POSITION HEADER ASSEMBLIES
- 4 DIMENSION APPLIES AT BASE OF SHROUD
- 5 THE NOTED DIMENSIONS APPLY AT THE INTERSECTION OF THE POST AND HOUSING
- 6. NOTE DELETED
- 7 CONTACT AREAS PLATED WITH 0.76µm GOLD, SOLDER TAILS PLATED WITH 3.81µm TIN, ALL OVER 1.27µm NICKEL
- 8 FINISH: 0.03µm MIN GOLD ON GOLD PLATED AREA 3.81µm MATTE TIN-LEAD ON TIN PLATED AREA. UNDER PLATING TO BE 1.27µm NICKEL ON ENTIRE CONTACT.
- 9. NOTE DELETED.
- 10. NOTE DELETED.
- 11. NOTE DELETED
- 12. NOTE DELETED
- 13 FINISH: 0.03µm MIN GOLD ON GOLD PLATED AREA 3.81µm MATTE TIN ON TIN PLATED AREA. UNDER PLATING TO BE 1.27µm NICKEL ON ENTIRE CONTACT.
- 14 MATERIAL: HOUSING-LCP, COLOR-BLACK CONTACT-COPPER ALLOY

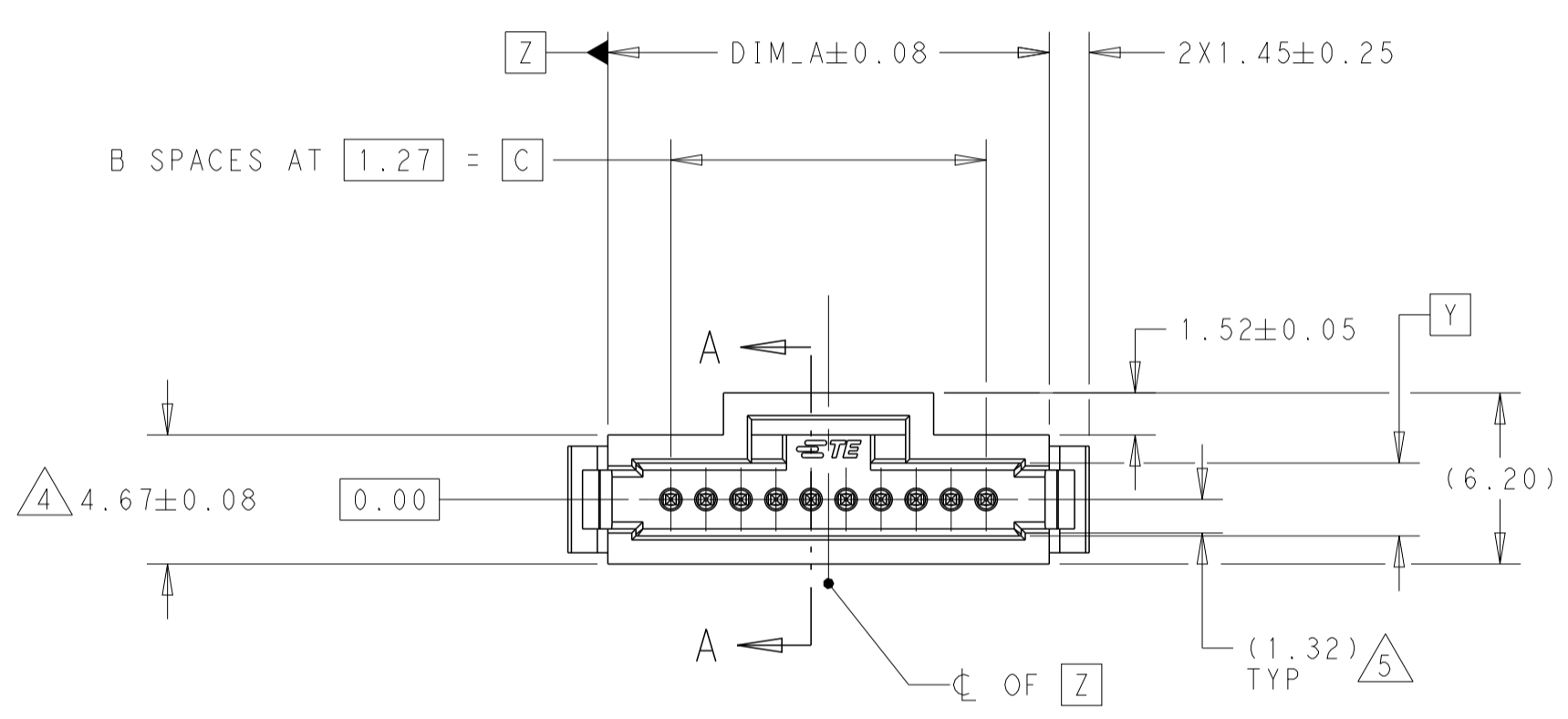
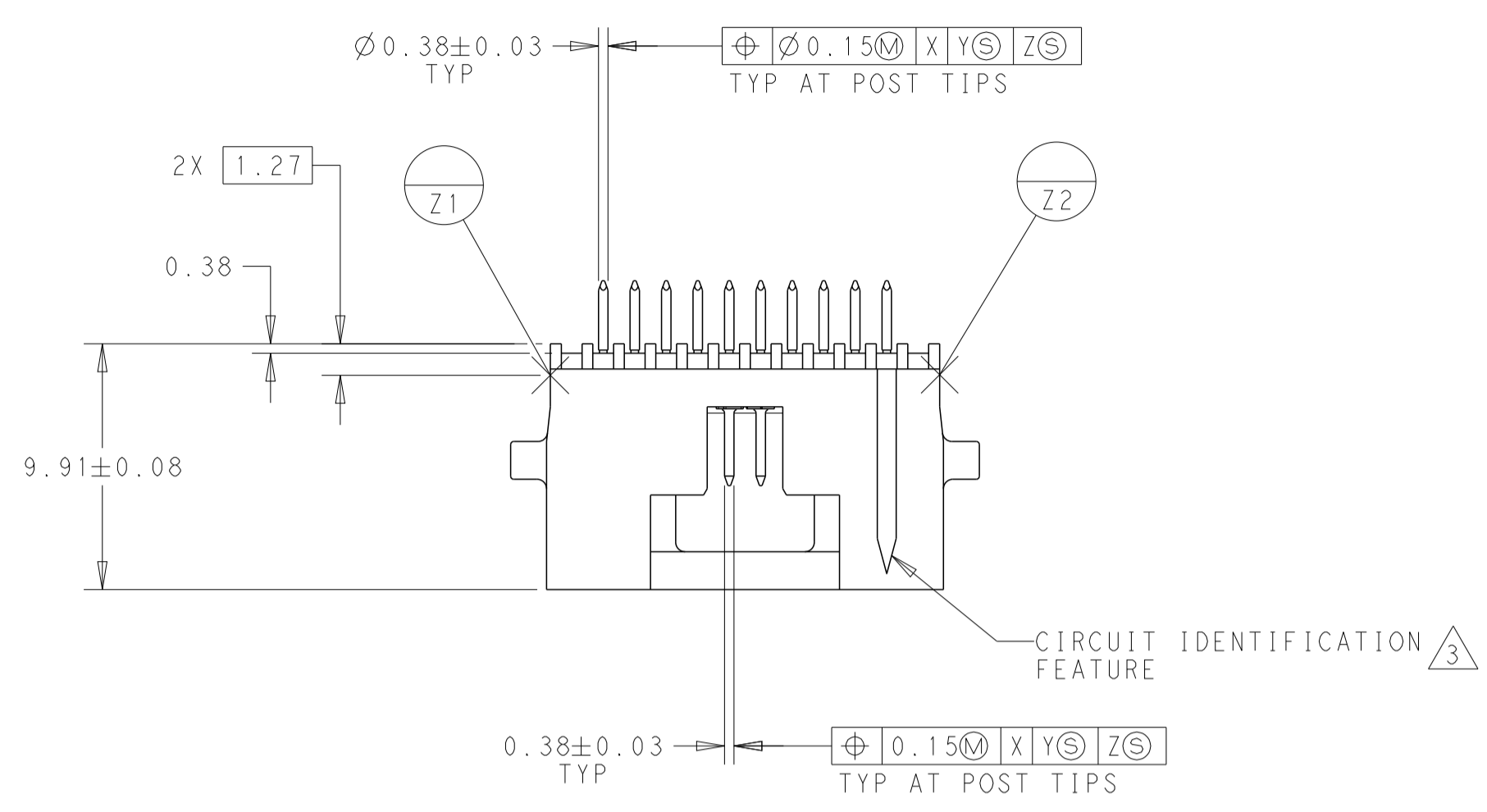
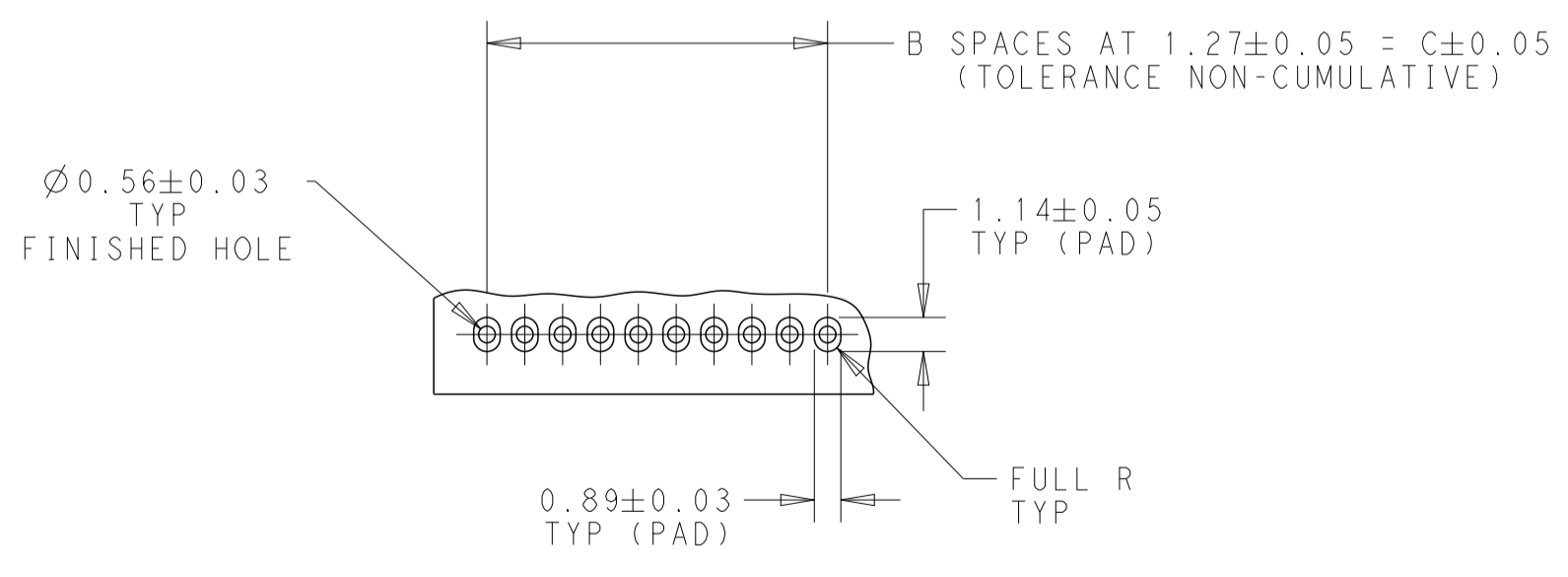

RECOMMENDED HOLE PATTERN

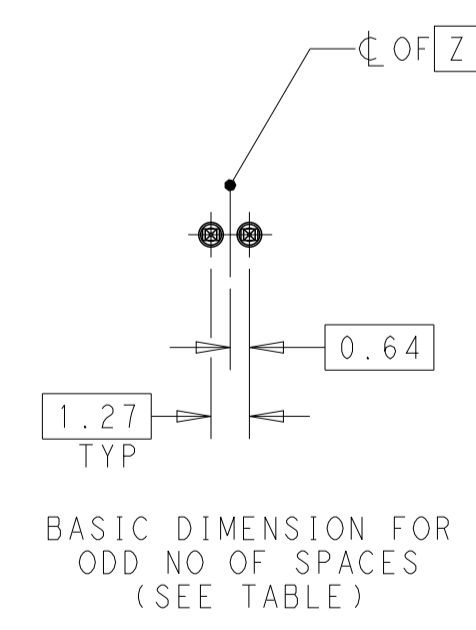

BASIC DIMENSION FOR ODD NO OF SPACES (SEE TABLE)

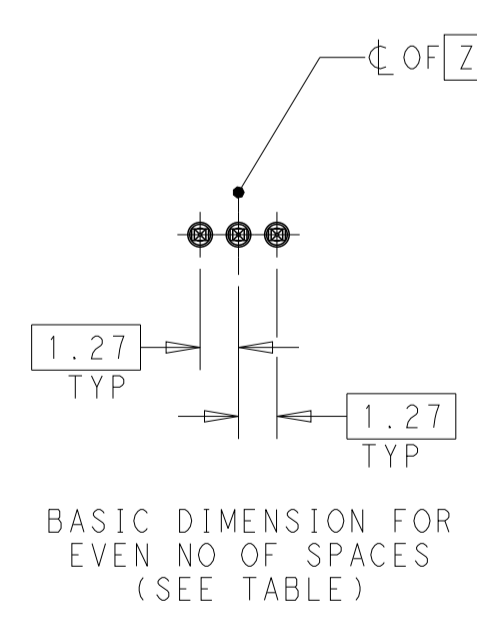

BASIC DIMENSION FOR EVEN NO OF SPACES (SEE TABLE)

FOR TABLE SEE SHT-2

THIS DRAWING IS A CONTROLLED DOCUMENT.		OWN: RL KOLLER 25JUL2017	TE Connectivity	
DIMENSIONS: mm		CHK: J. OLSON 27JUL2017		
TOLERANCES UNLESS OTHERWISE SPECIFIED:		APVD: J. OLSON 27JUL2017	NAME: HEADER ASSEMBLY, VERTICAL SINGLE ROW W/LATCHES AMPMODU SYSTEM 50	
0 PLC	±	PRODUCT SPEC	SIZE: CAGE CODE DRAWING NO	
2 PLC	±0.3	108-1093	RESTRICTED TO	
3 PLC	±0.13	APPLICATION SPEC	A100779C=104071	
4 PLC	±	114-25031	SCALE: 4:1 SHEET 1 OF 2 REV R	
ANGLES	±0.5°	WEIGHT		
FINISH	SEE TABLE	CUSTOMER DRAWING		

THIS DRAWING IS UNPUBLISHED. RELEASED FOR PUBLICATION
 © COPYRIGHT copyright dbt ALL RIGHTS RESERVED.

REVISIONS				
P	LTN	DESCRIPTION	DATE	APVD
-		SEE SHEET 1	-	-

3	31.75	25	36.32	26	9-104071-0
	62.23	49	66.80	50	8-104071-9
	55.88	44	60.45	45	8-104071-8
	49.53	39	54.10	40	8-104071-7
	44.45	35	49.02	36	8-104071-6
	33.02	26	37.59	27	8-104071-5
	26.67	21	31.24	22	8-104071-4
	20.32	16	24.89	17	8-104071-3
	15.24	12	19.81	13	8-104071-2
	13.97	11	18.54	12	8-104071-1
	8.89	7	13.46	8	8-104071-0
	7.62	6	12.19	7	7-104071-9
	6.35	5	10.92	6	7-104071-8
	3.81	3	8.38	4	7-104071-7
	36.83	29	41.40	30	7-104071-6
	30.48	24	35.05	25	7-104071-5
	24.13	19	28.70	20	7-104071-4
	17.78	14	22.35	15	7-104071-3
	5.08	4	9.65	5	7-104071-2
	11.43	9	16.00	10	7-104071-1
7	31.75	25	36.32	26	7-104071-0
	62.23	49	66.8	50	6-104071-9
	55.88	44	60.45	45	6-104071-8
	49.53	39	54.10	40	6-104071-7
	44.45	35	49.02	36	6-104071-6
	33.02	26	37.59	27	6-104071-5
	26.67	21	31.24	22	6-104071-4
	20.32	16	24.89	17	6-104071-3
	15.24	12	19.81	13	6-104071-2
	13.97	11	18.54	12	6-104071-1
	8.89	7	13.46	8	6-104071-0
	7.62	6	12.19	7	5-104071-9
	6.35	5	10.92	6	5-104071-8
	3.81	3	8.38	4	5-104071-7
	36.83	29	41.40	30	5-104071-6
	30.48	24	35.05	25	5-104071-5
	24.13	19	28.70	20	5-104071-4
	17.78	14	22.35	15	5-104071-3
	5.08	4	9.65	5	5-104071-2
	11.43	9	16.00	10	5-104071-1
FINISH	DIM_C	B SPACES	DIM_A	NO OF POSN	PART NUMBER

8	31.75	25	36.32	26	4-104071-0
	62.23	49	66.80	50	3-104071-9
	55.88	44	60.45	45	3-104071-8
	49.53	39	54.10	40	3-104071-7
	44.45	35	49.02	36	3-104071-6
	33.02	26	37.59	27	3-104071-5
	26.67	21	31.24	22	3-104071-4
	20.32	16	24.89	17	3-104071-3
	15.24	12	19.81	13	3-104071-2
	13.97	11	18.54	12	3-104071-1
	8.89	7	13.46	8	3-104071-0
	7.62	6	12.19	7	2-104071-9
	6.35	5	10.92	6	2-104071-8
	3.81	3	8.38	4	2-104071-7
	36.83	29	41.40	30	2-104071-6
	30.48	24	35.05	25	2-104071-5
	24.13	19	28.70	20	2-104071-4
	17.78	14	22.35	15	2-104071-3
	5.08	4	9.65	5	2-104071-2
	11.43	9	16.00	10	2-104071-1
1	31.75	25	36.32	26	2-104071-0
	62.23	49	66.80	50	1-104071-9
	55.88	44	60.45	45	1-104071-8
	49.53	39	54.10	40	1-104071-7
	44.45	35	49.02	36	1-104071-6
	33.02	26	37.59	27	1-104071-5
	26.67	21	31.24	22	1-104071-4
	20.32	16	24.89	17	1-104071-3
	15.24	12	19.81	13	1-104071-2
	13.97	11	18.54	12	1-104071-1
	8.89	7	13.46	8	1-104071-0
	7.62	6	12.19	7	104071-9
	6.35	5	10.92	6	104071-8
	3.81	3	8.38	4	104071-7
	36.83	29	41.40	30	104071-6
	30.48	24	35.05	25	104071-5
	24.13	19	28.70	20	104071-4
	17.78	14	22.35	15	104071-3
	5.08	4	9.65	5	104071-2
	11.43	9	16.00	10	104071-1
FINISH	DIM_C	B SPACES	DIM_A	NO OF POSN	PART NUMBER

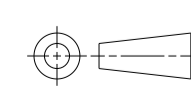
THIS DRAWING IS A CONTROLLED DOCUMENT.		DWN R. SHRISHALLI 25JUL2017 CHK J. OLSON 27JUL2017 APVD J. OLSON 27JUL2017	 TE Connectivity	
DIMENSIONS: mm 	TOLERANCES UNLESS OTHERWISE SPECIFIED: 0 PLC ± 1 PLC ±0.3 2 PLC ±0.13 3 PLC ± 4 PLC ± ANGLES ±0.5° FINISH	NAME HEARER ASSEMBLY, VERTICAL SINGLE ROW W/LATCHES AMPMODU SYSTEM 50 PRODUCT SPEC 108-1093 APPLICATION SPEC 114-25031	SIZE A100779 CAGE CODE C=104071 DRAWING NO.	RESTRICTED TO - SCALE 5:1 SHEET 2 OF 2 REV R
MATERIAL - SEE TABLE		CUSTOMER DRAWING		